

MODEL NUMBER SYSTEM

EXAMPLE: **DP X 1200 -52**

SP = Single Pair High
 DP = Double Pair High
 TP = Triple Pair High

X = Lower Horsepower
 HX = Higher Horsepower

Roll Diameter
 1200=12 inches (305 mm)
 1400=14 inches (356 mm)
 1600=16 inches (406 mm)

Roll Length (in inches)

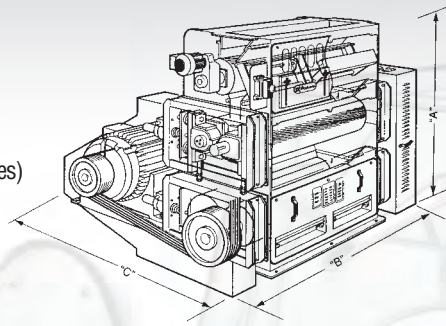

X/HX 1200/1400/1600
**CRACKING
 MILL**

MODEL	HP RANGE	"A" HEIGHT INCHES (MM)	"B" WIDTH INCHES (MM)	"C" DEPTH INCHES (MM)	APPROX. WEIGHT LBS. (KG.)
SPX-1200-24	15-20	46.00 (1168)	68.88 (1750)	85.00 (2159)	6,850 (3114)
SPX-1200-30	20-25	46.00 (1168)	74.88 (1902)	85.00 (2159)	7,250 (3296)
SPX-1200-36	25-30	46.00 (1168)	80.88 (2054)	85.00 (2159)	7,650 (3477)
SPX-1200-42	30-40	46.00 (1168)	86.50 (2197)	88.00 (2235)	8,050 (3659)
SPX-1200-52	40-50	46.00 (1168)	96.50 (2451)	88.00 (2235)	8,700 (3955)
SPX-1200-72	50-60	46.00 (1168)	116.50 (2959)	88.00 (2235)	9,500 (4319)
SPHX-1400-72	60-75	46.00 (1168)	117.88 (2994)	96.00 (2438)	10,500 (4773)
SPHX-1600-52	50-60	46.00 (1168)	97.63 (2480)	96.00 (2438)	10,000 (4545)
SPHX-1600-72	60-75	46.00 (1168)	117.88 (2994)	96.00 (2438)	11,000 (5000)
SPHX-1600-84	60-75	46.00 (1168)	129.63 (3293)	96.00 (2438)	12,100 (5500)
DPX-1200-24	30-40	70.00 (1778)	68.88 (1750)	85.00 (2159)	10,700 (4864)
DPX-1200-30	40-50	70.00 (1778)	74.88 (1902)	85.00 (2159)	11,500 (5227)
DPX-1200-36	50-60	70.00 (1778)	80.88 (2054)	85.00 (2159)	12,300 (5591)
DPX-1200-42	60-75	70.00 (1778)	86.50 (2197)	88.00 (2235)	13,100 (5955)
DPX-1200-52	75-100	70.00 (1778)	96.50 (2451)	88.00 (2235)	14,400 (6546)
DPX-1200-72	100-125	70.00 (1778)	116.50 (2959)	88.00 (2235)	17,000 (7727)
DPHX-1400-72	125-150	70.00 (1778)	117.88 (2994)	96.00 (2438)	21,000 (9545)
DPHX-1600-52	100-125	70.00 (1778)	97.63 (2480)	96.00 (2438)	19,500 (8864)
DPHX-1600-72	125-150	70.00 (1778)	117.88 (2994)	96.00 (2438)	23,000 (10455)
DPHX-1600-84	125-150	70.00 (1778)	129.63 (3293)	96.00 (2438)	25,000 (11364)

Weights and dimensions subject to change. Do not use for layout purposes.



CPM/Roskamp Champion
 2975 Airline Circle
 Waterloo, IA 50703
 (319) 232-8444
 (800) 366-2563
 fax: (319) 236-0481
 sales@cpmroskamp.com

CPM/Europe BV
 Distelweg 89
 1031 HD Amsterdam
 Netherlands
 Tel (31) 20 494 61 11
 Fax (31) 20 636 42 94
 info@cpmeurope.nl

CPM/Pacific Private Ltd.
 17 Liu Fang Road
 Singapore 2262
 Republic of Singapore
 Tel 65-62650701
 Fax 65-62686428
 cus.svc@cpmasia.com

CPM Machinery (Wuxi) Co.Ltd.
 10 Xin Du Road
 Jiangsu, China 214028
 Tel 86 0510 8528 0487
 Fax 86 0510 8528 2429
 cus.wx@cpmasia.com



**ROSKAMP
 CHAMPION**
Your Partner in Productivity

BUILT FOR PERFORMANCE. BUILT TO LAST.

Designed for the most demanding oilseed applications, the robust construction of the Roskamp Cracking Mill guarantees maximum performance around the clock.

Load-centering bearing supports and unique bearing slides assure accurate, consistent production. Roll corrugation and speed differential ratios are available to match any operating condition.

The Roskamp Cracking Mill delivers everything you expect from your machine.



DPHX1400-72



DPHX 1200-72

Rolls & Shafts

Rolls are of the highest quality straight carbon clear chill cast iron. All rolls are cast, machined and ground to the highest technical specifications. Depth of chill is a minimum of .625 inches (16mm). Allows custom corrugating for specific product configurations.

Large diameter shafts are high strength alloy steel. Roll bodies and shafts are precisely machined to assure concentricity.

Bearings, Housings & Slide Blocks

Roll shaft bearings are self-aligning spherical roller bearings. Tapered bearing bore with adapter sleeve provides positive locking fit with shaft to prevent shaft fretting. All bearing lube ports are easily identified and accessible for maintenance. Bearing housings and slide blocks assure positive roll tram (maintaining rolls in same horizontal plane) for positive particle size control and to assure the best roll life.

Roll Adjustment

One-point roll adjustment is made by machine screw jacks. Rolls remain in parallel throughout the adjustment range. Positive roll stop offers maximum protection against roll-to-roll contact.

Inter-Roll Drives

V-Belt inter-roll drives allow for quiet operation in all applications (up to 75 H.P. per pair). Belt tension can be adjusted without removing the guard. Heavy-duty idler arrangement keeps belts positively tensioned.

Main Drive and Motor Base

The main drive (motor to rolls) is 5V section V-Belt design. A separate motor base arrangement is designed to accept standard motor frames.

Roll Housing/Frame

Front and rear cast and machined pressure members with interlocking tension members contain the roll separating forces. Machine jack screws and engineered spring stacks fix rolls in position, yet open to bypass uncrushable materials to protect rolls and shafts. The robust design is a key element in the overall strength of the mill and provides the platform suited to any oilseed application.

Roll Housing Frame

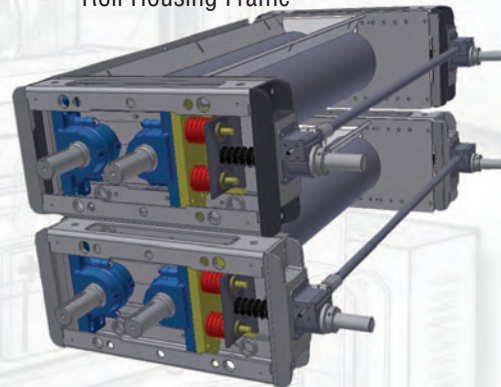

Inter-Roll Drive

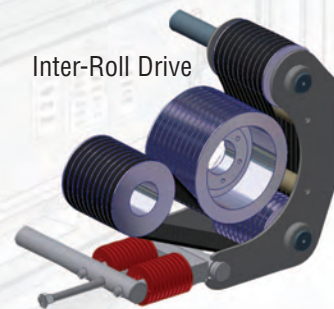

Model 1200/1400/1600 Cracking Mill Options

Roll Feeder

A roll feeder with separate drive is combined with an adjustable feedgate for more precise feed rate control. Air actuated or manual feedgate options are available.

Pocket Feeder

A volumetric rotary pocket feeder with separate drive is available as an alternative to a roll feeder. This allows flow rate control and positive shutoff through the use of a variable frequency drive. The pocket feeder can easily be adapted to automated load control.

Magnet

Heavy-duty permanent magnets remove tramp iron from the product stream. Magnets swing out of the feeder housing for ease of cleaning.

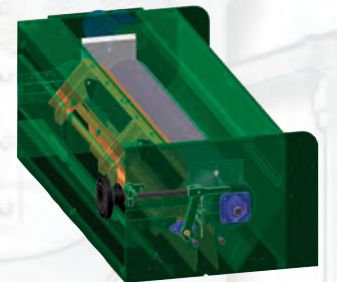

Roll Feeder



Pocket Feeder

CRACKING MILL CAPACITY

MODEL	ROLL SURFACE AREA (IN ²)	SOYBEAN CAPACITY (MTD)
DPX-1200-24	904	300
DPX-1200-30	1130	400
DPX-1200-36	1357	500
DPX-1200-42	1583	600
DPX-1200-52	1960	750
DPX-1200-72	2714	1000
DPHX-1400-72	3166	1250
DPHX-1600-52	2613	1000
DPHX-1600-72	3619	1350
DPHX-1600-84	4222	1550

Roskamp Champion's Strategic Advantage

The ability to deliver to the customer the best "Value Package." In other words, in the long-term, when all things are considered, we offer customers equipment and services that represent the lowest operating cost solution.